



# PCL-1

## SOFT SERVE & FROZEN DRINK MACHINE

The PCL-1 is the smallest and lightest commercial soft serve machine in the world. With a simple, user friendly, and compact design, the PCL-1 brings soft serve capability to any location. The PCL-1 utilizes automatic consistency control for smooth and creamy product with every serving.

## Features

- Self-contained air cooled countertop model
- Smallest footprint in the industry for a commercial soft serve machine
- Serves frozen yogurt, sorbet, custard, soft serve ice cream, gelato, and frozen slush products
- Refrigerated hopper for faster recovery times
- 14-18 minute typical freeze time to first dispense frozen product
- Automatic consistency control for easy operation
- Direct drive motor for reduced noise
- Dishwasher safe components for easy



Intertek



Intertek



CE ISO 9001

30798 Kingsland Blvd.,  
Ste 200 / BLDG B  
Katy, Texas 77423

**DONNIECOOLS**  
info@donniecools.com  
www.donniecools.com

Side View

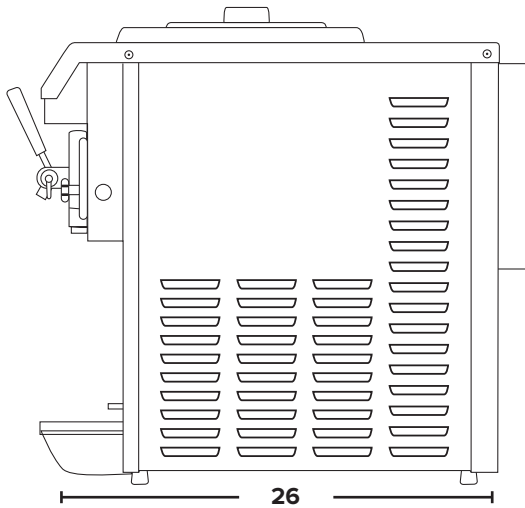

Front View

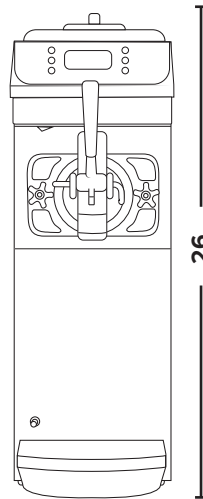

Top View

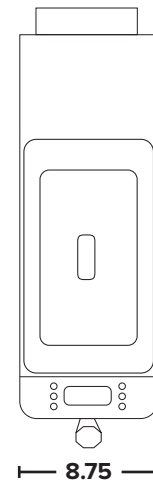

Measurements in inches.

## Size and Capacity

Freezing Cylinder	1.25 Qt (1.18 L)
Hopper	3.75 Qt (5 L)
Appx. Hourly Production	10 Qt (11.4 L)
Height	26 in (660 mm)
Width	8.75 in (222 mm)
Depth	26 in (660 mm)
Weight	90 lbs (41 kg)

## Electrical

Voltage	115 v
Phase	Single
Rated Input Power	500 W
Compressor	1/3 HP
Hertz	60 Hz
Plug Type	115 volt Standard Plug

## Distributed By:

---



30798 Kingsland Blvd.,  
Ste 200 / BLDG B  
Katy, Texas 77423

**DONNIECOOLS**  
info@donniecools.com  
www.donniecools.com