



PC-3C-3X6 FROZEN BEVERAGE MACHINE

The PC-3C-3X6 is a high volume slush machine designed for reliability and ease of use in an attractive mirror stainless finish that accents any placement. The PC-3C-3X6 offers an energy efficient refrigeration system for low cost operation, oversized LED backlit signage for merchandising appeal and no heat to melt the slush product, and simple controls for easy operation and perfect slush every time.

Features

- Large 3.2 gallon bowls (x3) for high volume applications
- Night time refrigeration mode for energy savings and to minimize cleaning
- Simple switch control functions for reliability and cost efficient maintenance
- Independently operable bowls for flexibility to run one or two flavors
- Variable consistency control for perfect slush with any product
- Removable drip trays for easy draining and cleaning
- Mirror stainless steel with black trim for an attractive finish that is easy to clean



Intertek



Intertek



CE ISO 9001

30798 Kingsland Blvd.,
Ste 200 / BLDG B
Katy, Texas 77423

DONNIECOOLS
info@donniecools.com
www.donniecools.com

PC3C-3X6

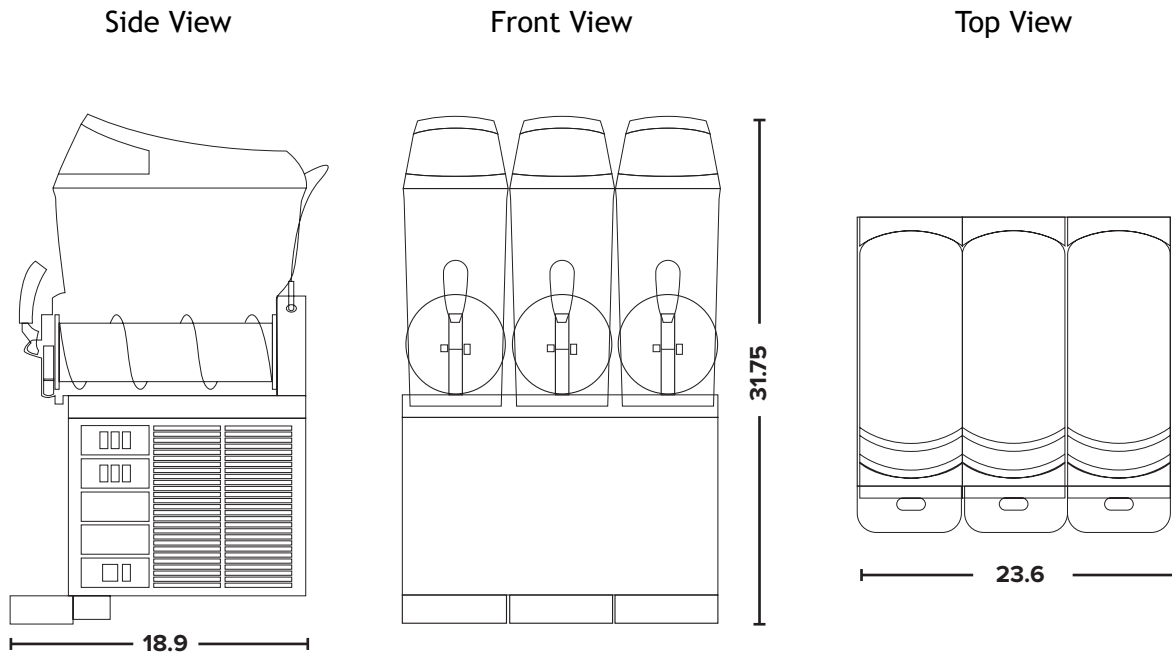

Measurements in inches.

Size and Capacity

Refrigerated Hoppers (each)	12.7 Qt (12 L)
Refrigerant	R290*
Height	31.75 in (806 mm)
Width	23.6 in (600 mm)
Depth	18.9 in (480 mm)
Weight	102 lbs (46 kg)

Electrical

Voltage	115 v
Phase	Single
Rated Input Power	1,100 W
Compressor	1 HP
Hertz	60 Hz
Plug type	L5 20P

Distributed By:



30798 Kingsland Blvd.,
Ste 200 / BLDG B
Katy, Texas 77423

DONNIECOOLS
info@donniecools.com
www.donniecools.com