



CE ISO 9001

## PC 1C-X2 FROZEN BEVERAGE MACHINE

The PC 1C-X2 is a high-volume slush machine designed for reliability and ease of use in an attractive mirror stainless finish that accents any placement. The PC 1C-X2 offers an energy efficient refrigeration system for low-cost operation, oversized LED backlit signage for merchandising appeal and no heat to melt the slush product, and simple controls for easy operation and perfect slush every time.

### Features

- Large 3.2 gallon bowl for high volume applications
- Night time refrigeration mode for energy savings and to minimize cleaning
- Simple switch control functions for reliability and cost efficient maintenance
- Variable consistency control for perfect slush with any product
- Removable drip tray for easy draining and cleaning
- Mirror stainless steel with black trim for an attractive finish that is easy to clean

 **ProCool**

30798 Kingsland Blvd.,  
Ste 200 / BLDG B  
Katy, Texas 77423

**DONNIECOOLS**  
info@donniecools.com  
www.donniecools.com

# PC 1C-X2

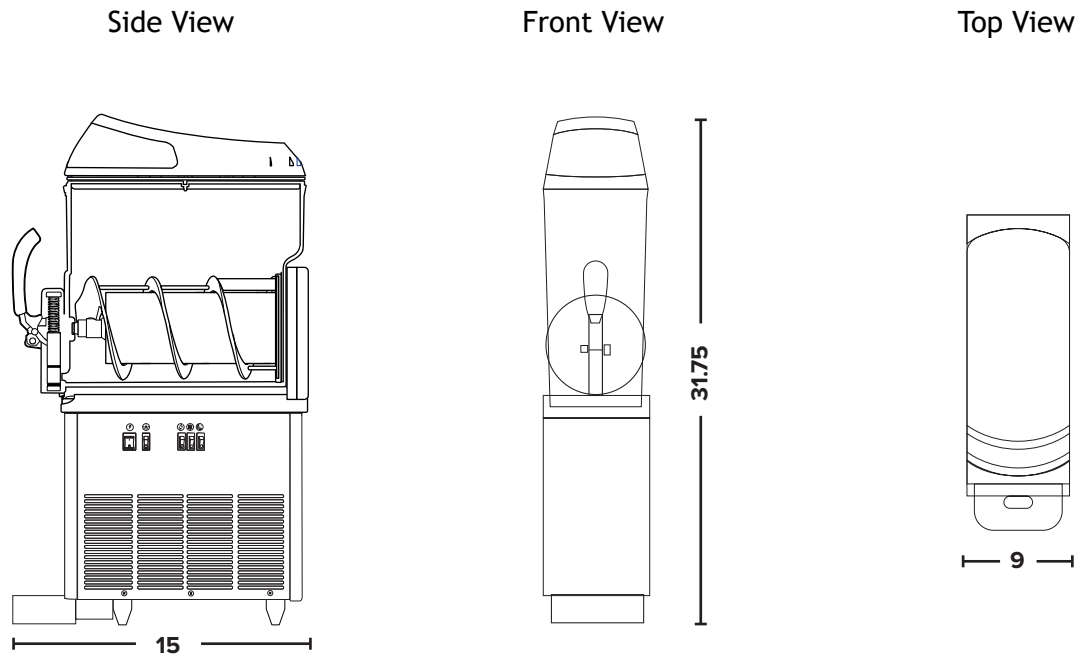

Measurements in inches.

## Size and Capacity

Refrigerated Hopper	12.7 Qt (12 L)
Height	31.75 in (806 mm)
Width	9 in (229 mm)
Depth	15 in (381 mm)
Weight	69 lbs (31 kg)

## Electrical

Voltage	115 v
Phase	Single
Rated Input Power	700 W
Compressor	1/3 HP
Hertz	60 Hz
Plug type	115 volt Standard Plug

**Distributed By:**

---



30798 Kingsland Blvd.,  
Ste 200 / BLDG B  
Katy, Texas 77423

**DONNIECOOLS**  
info@donniecools.com  
www.donniecools.com